

How to make a parallel circuit

If you want to put more than one component in a circuit you may find putting them in series (see the sheet on 'How to make a series circuit' if you are unsure what this is) will not work. You may find bulbs do not light up or are not very bright, motors run slowly or buzzers are quiet. Making a parallel circuit can help.

This is all about **RESISTANCE**. Think about your Engineering Apprenticeship and what you learnt about resistance there. In a parallel circuit you give the electricity two routes to flow through rather than just one.

Try this:

1. Connect a circuit which has a buzzer and a motor in series as shown in the diagram below.

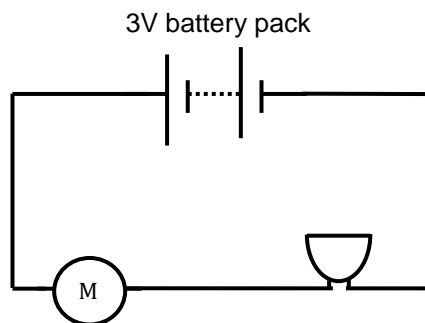

2. Now connect them in parallel as shown in the diagram below. Does this make a difference?

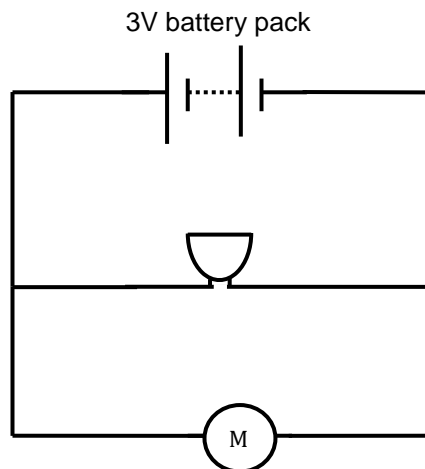

How could you use this in your product design?

How to make a pneumatic system

In a pneumatic system compressed air can be used to move/lift things. You can make it as shown below:

1. Pull the plunger of each syringe so that it is half way out (around 5ml reading on the scale).



2. Connect the plastic tube onto the ends of both syringes.

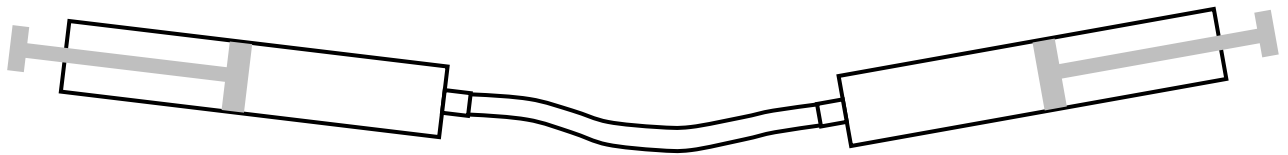

3. Push the plunger on one syringe and watch what happens to the other syringe.

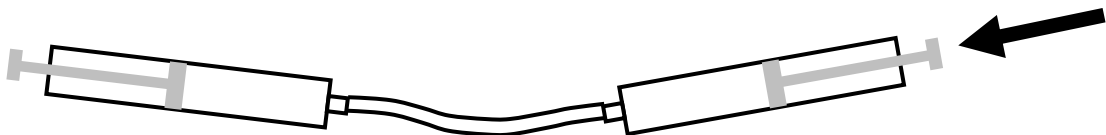

How could you use this in your product design?

How to make a pressure pad

A pressure pad can be used as a switch in your circuit. It works by making a connection between two conductive layers (tin foil) when pressed down and breaking the circuit when something stops pushing it down and the sponge separates the two layers of tin foil.

You can make it as shown below.

1. First cut a hole in the sponge.

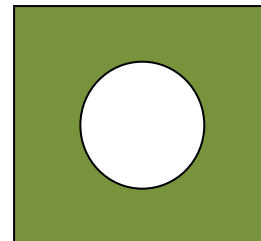

2. Then cut two pieces of foil the same size as the piece of sponge and tape one on the top and one on the bottom. These **MUST NOT** touch if the sponge is not pressed down but should once it is pressed

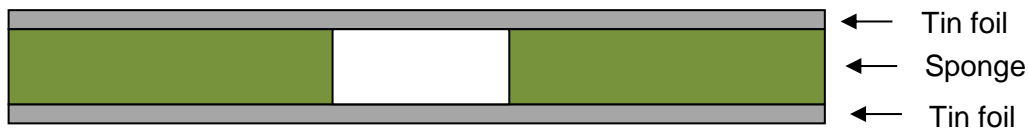

3. Then attach one crocodile lead to the top piece of foil and another to the bottom piece.

Attach crocodile
lead here

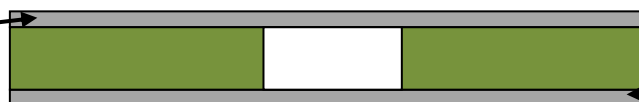

Attach crocodile
lead here

4. You can then put it in your circuit just like a switch and press it to make a bulb or LED light up, a buzzer sound or a motor begin working.

How could you use this in your product design?

How to make a series circuit

For electricity to flow around a circuit we must have the following:

- a power source such as a battery;
- a conducting material which connects the positive and negative terminals of our battery;
- no breaks in the circuit.

However, if we made this circuit we would soon find the battery and the wires would quickly get very hot as there is no component which creates greater resistance and slows down the flow of electricity. We call this a **SHORT CIRCUIT**. This can cause burns or even a fire.

By including an electrical component (or **OUTPUT**) we can slow down the flow of electricity and use it to make something useful happen. This could be:

- a bulb or LED lights up;
- a buzzer makes a sound;
- a motor spins round.

Make this circuit and see what happens when you disconnect the crocodile lead from the positive terminal of the battery.

Now put a buzzer or a motor instead of a bulb. Do you have to connect the buzzer or motor a particular way round?

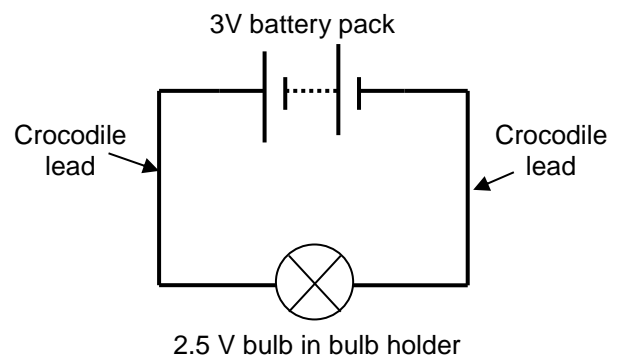

We can also include electrical components which will change the ways in which things happen. For example, if we put a bulb or LED in our circuit we could also include:

- an **LDR** to vary the flow of electricity and make the LED glow more or less bright. This will only work with an LED and not a 2.5V bulb because of the level of resistance.
- a **POTENTIOMETER** to vary the flow of electricity and make the bulb or LED glow more or less bright.
- a **SWITCH** to break the circuit and turn the bulb or LED on or off.

We can also change the **VOLTAGE** in a circuit. This is the power available to push the flow of electricity around a circuit. This can make the bulb or LED glow more brightly. **BE CAREFUL** though, too high a voltage and the flow of electricity will be too great and the filament in the bulb will heat up too much and break.

How to use a moisture sensor

You can use a moisture sensor in your circuit as a simple switch. Connect it by attaching one crocodile lead to the top of one nail and another to the top of the other nail as in the diagram below.

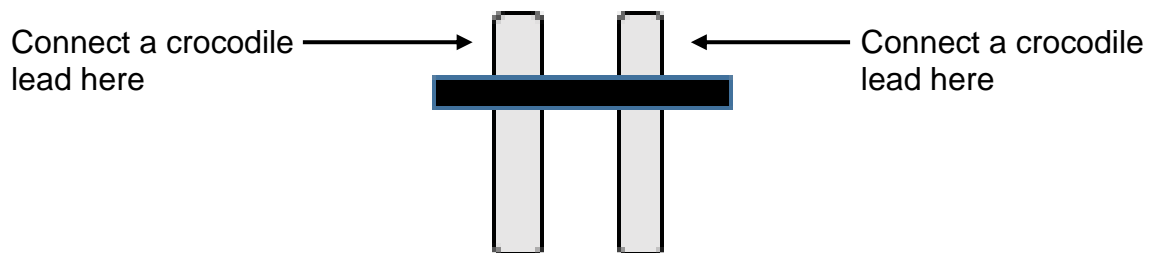

Remember your engineering apprenticeship on **RESISTANCE**? Different materials have different levels of resistance. Good conductors have low resistance, poor conductors have high resistance.

Water is quite a good conductor of electricity so, when you put the two nails into water, it will allow the electrical current to flow through the circuit. This will also work if you put the two nails against any material which conducts electricity.

Try it against different materials. Which materials conduct electricity and which do not?

How could you use this information to make your own switch?

How could you use this in your product design?

How to connect a potentiometer

A potentiometer is a variable resistor. It allows us to make the resistance in a circuit higher or lower and this changes the rate of flow of electricity. We can use this effect to change how electrical components behave.

IMPORTANT: Potentiometers work best with either LEDs or buzzers where we can make an LED glow more or less brightly or a buzzer sound louder or quieter. If you are using them with a 2.5V bulb or a motor they will only turn these components on or off.

Try making a circuit with a buzzer and potentiometer in it. Connect your potentiometer with one wire on the middle metal terminal and the other on either of the other two outside terminals (it doesn't matter which one) as shown below.

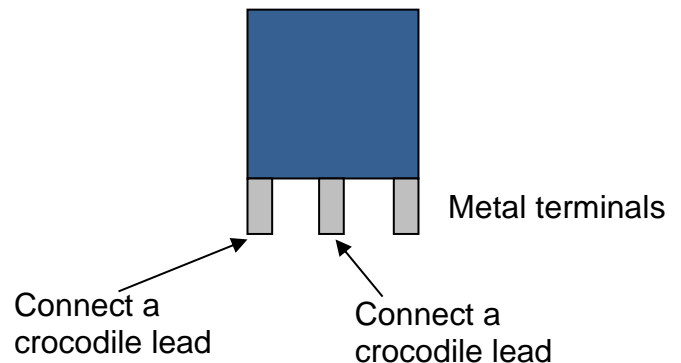

You will need to connect the potentiometer to the positive terminal of the battery and then connect your LED. **REMEMBER** that the longer leg of the LED must be connected in the circuit to the positive side of the battery.

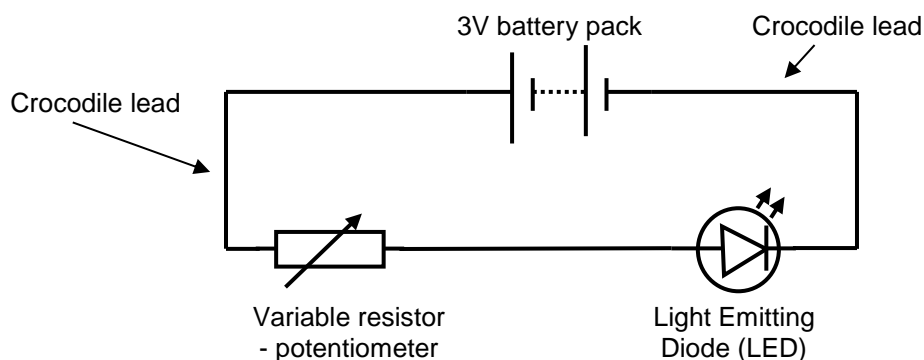

Now turn the control on the potentiometer to see what happens to the buzzer.

How could you use this in your product design?